

VAF

INSTRUMENTS



ViscoSense®2

Viscosity Measurement & Control Systems

753

Product Bulletin

WWW.VAF.NL

TO BE
REALLY
SURE

Introduction

Having over 50 years of experience and more than 50000 systems sold, VAF Instruments is the worldwide market leader for in-line viscosity measurement and control systems. ViscoSense®2 is the latest innovative development in a long history of outstanding viscosity sensors for fuel oil applications. In this most demanding environment of diesel engines on board ships and in land based power plants, VAF Instruments has proven itself with high quality products and a comprehensive and professional customer support.

Necessity of viscosity control

A large variation in the quality and composition of fuel oil, makes the behaviour of the fuel oil at higher temperatures difficult to predict. An optimal viscosity is needed for the best possible atomization of HFO in the engine, so the fuel will be burnt completely without remaining deposits. The measurement and control of the viscosity ensures an improved combustion efficiency, preventing engine damage and reduces cost of maintenance. Viscosity control contributes to a green environment.

Accuracy

ViscoSense®2 is a highly accurate viscosity sensor with a superior measuring principle. This patented measuring principle is based on a torsional vibration of a pendulum in liquid. The measured damping of this piezo-driven vibration is directly related to the viscosity. A built-in temperature sensor is used to measure the temperature at the same location where viscosity is measured.

Reliability

ViscoSense®2 is able to measure inline the actual dynamic viscosity of a large range of liquids. Due to the operating principle based on a torsional vibration, the measurement is insensitive to unwanted external influences. Flow velocity, flow direction and pulsations have no effect on the sensor operation. The robust built sensor is designed to operate under the most difficult conditions in which a faultless and stable viscosity measurement is required.

Cost-effective operation

The ViscoSense®2 sensor is developed to measure viscosity without interruptions and with low operating costs. Since the sensor does not actually move, it is not subject to wear and therefore it ensures a long lifetime and a maintenance free operation. The surface of the pendulum (which has undergone special surface treatment to improve its non-stick performances) in combination with a smooth edged design makes the sensor highly insensitive to fouling and easy to clean. The sensor is calibrated for life and the accuracy will be kept without the necessity of re-calibration. Due to its compact design, the sensor is suitable for easy installation in any new or retrofit system.

Quality

VAF Instruments demonstrates its trust in its products by giving a standard two year guarantee. This longest and most comprehensive guarantee in the maritime industry is our commitment to our clients and reflects the constant quality of our products.

ViscoSense®2 is a registered trade mark of VAF Instruments

Principle of operation

The operating principle of the sensor is that of a torsion pendulum. The sensor consists of a stainless steel driver/sensor head, attached to the base plate by means of a tubular torsion spring. In the head, one pair of piezo elements (driver piezos) actuates the pendulum at its torsional resonance frequency, while another pair of receiver piezos detects the actual movement of the head. In a low viscosity medium, like air, the resonance frequency is in the range of 1600 Hz. In a high viscosity medium the movement of the head is damped by the liquid. Consequently, the resonance frequency slightly shifts towards lower frequencies, whilst the width of the resonance peak increases, which is a measure for the viscosity.

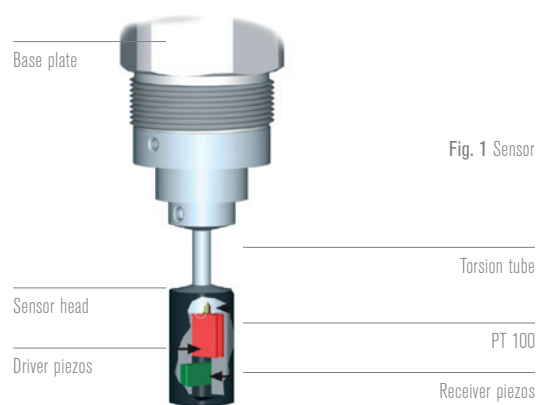
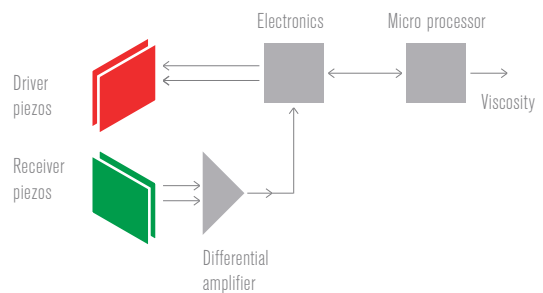
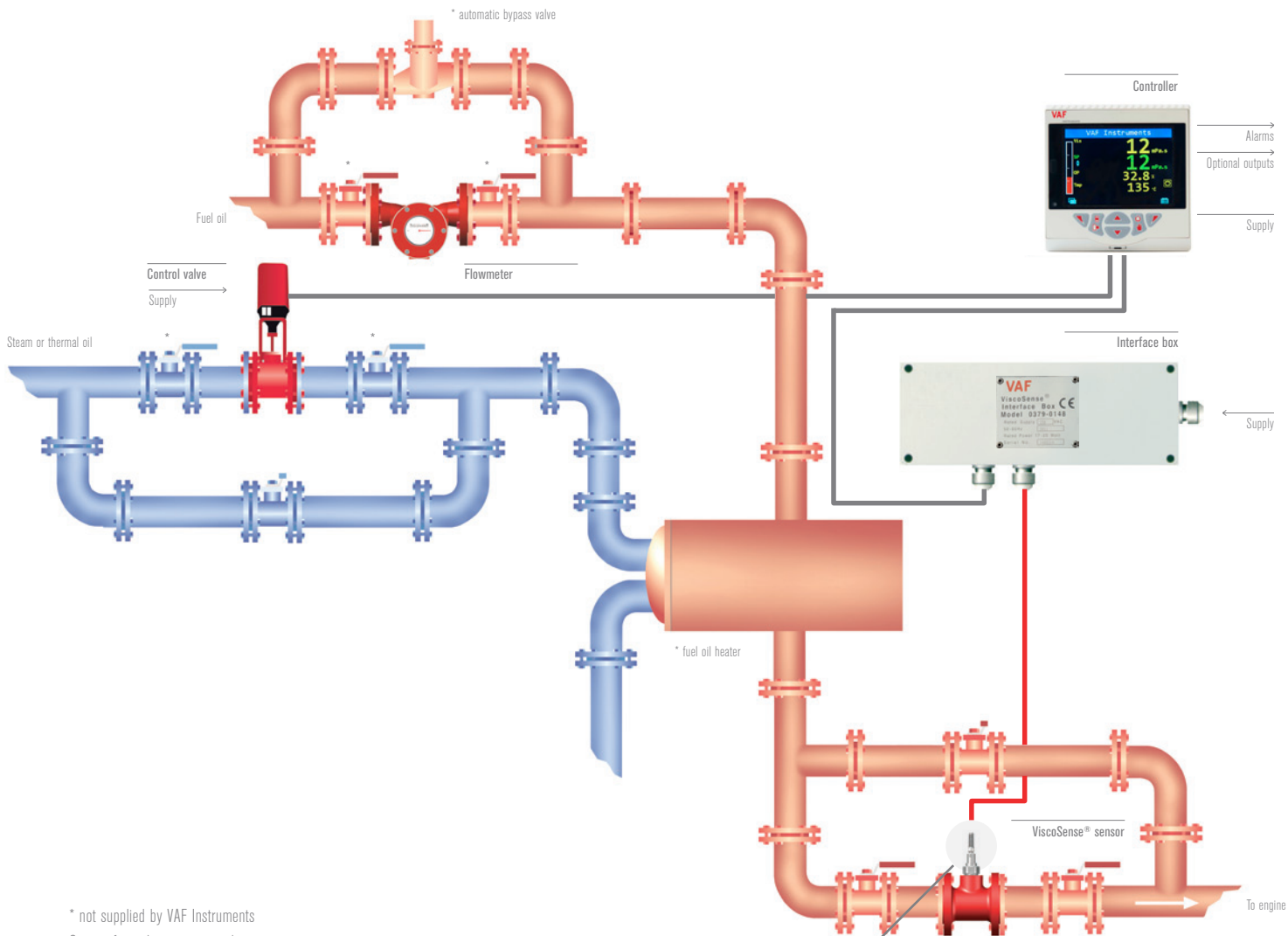

Fig. 1 Sensor

Typical system arrangement



* not supplied by VAF Instruments
Scope of supply is customized



Features & benefits

As a result of the torsional vibration technique, the flow velocity has no effect on the measurement. External vibrations have no influence on the accuracy of the ViscoSense®2. In practice the smooth edged design of the stainless steel sensor makes the system highly insensitive to fouling and easy to clean. On top of that the closed-loop controlled torsional vibration principle, as illustrated, is independent of ageing of piezo material, ensuring long term stable and accurate measurement.

Features	Benefits
Stable and accurate in-line measurement	Optimal burning efficiency and fuel consumption Engine damage prevention and reduced maintenance
No moving parts	No preventive maintenance required Low operating costs
Compact light-weight construction	Easy to install
Stainless steel 316L pendulum	No wear due to corrosion Durable Minimal fouling
Smooth edged pendulum	Insensitive to adherence Reliable under all circumstances
Torsional vibration measuring principle	Not influenced by vibrations, flow velocity or dirt particles No down time
Minimal load on components	Minimal ageing and wear effects
Calibrated for life	Long and trouble-free operation No operator training required
Both viscosity and temperature outputs	No need for separate PT 100 transmitter
A genuine VAF Instruments product	Over 70 years of experience World market leader in viscosity control systems
Type approval from all major classification authorities	To be implemented directly on any ship without additional costs
Manufactured by a NEN-EN-ISO 9001 certificated organisation	Assured constant product quality

Technical specification

Sensor

Viscosity range	0-25 or 0-50 mPa.s for fuel oil applications; other ranges on request (up to 1000 mPa.s)
Accuracy viscosity	± 2% instantaneous with a minimum of 0,5 mPa.s
Temperature	± 1°C
Liquid temperature	Max. 180°C
Sensor materials	Stainless steel 316L
Protection class	IP65
Weight	1 kg
Note	For Exd versions consult factory

Interface box

Supply voltage	115/230 VAC, 50/60 Hz selectable (fluctuations should not exceed ±10% of the nominal voltage)
Power consumption	17-25 Watt
Output	
Viscosity	Active output 4-20 mA (maximum load 400 Ohm)
Range	0-25 or 0-50 mPa.s for fuel oil applications; other ranges on request (up to 1000 mPa.s)
Temperature	Active output 4-20 mA (maximum load 400 Ohm)
Range	0-200°C
Response time	Less than 1 minute
Resolution	0,1 mPa.s
Ambient temperature	-20 .. +55°C
Humidity range	0 .. 95% RH
Protection class	IP65
Mounting	Wall mounting
Installation category	I acc. IEC 1010-10
Pollution degree	I acc. IEC 664
Weight	3 kg

Controller

General	PI control function
Power supply	100-240 VAC, 48-62 Hz (fluctuations should not exceed ±10% of the nominal voltage)
Power consumption	10 W
Housing for panel mounting	96 x 96 mm
Operator controls	Up/down push buttons, menu button, auto/manual button, access level button
Ambient temperature	0-55°C
Operating humidity range	5-95% RH (non-condensing)
Protection class	IP66/NEMA 4X (front only)
Electronic connections	Screw terminals, accept wire size 0,5-1,5mm (16 to 22 Awg)
Weight	0,5 kg

Controls

Control strategy	Single channel or dual channel
Input viscosity	4-20 mA
Input temperature	4-20 mA (optional)
Output control contacts	2 relays, 5A/240 VAC (standard)
Output control action	If measured value is higher than setpoint value, the "open" output relay is activated to open control valve (viscosity control)
Output current	galvanically isolated 4-20 mA for retransmission
Alarm feature	Non-latching band alarm, adjustable 1 potential-free SPDT contact, 5A/240 VAC rating (NC fail safe)

Read-out

Display	Fully graphic display 1/4" VGA TFT with backlight
Scale range viscosity	0-25 mPa.s / 0-50 mPa.s (or as ordered)
Scale range temperature	0-200° C (optional)
Alarm indication	By means of one dedicated alarmbar in display
Output indication	By means of "open/close" messages



Interface box



Electronic controller

Technical specification

Housing

Material	Ductile iron
Flange connections	Standard DN50 (2"), DIN, ANSI or JIS; other sizes on request
Pressure rating	PN40
Weight	10 kg
Flow rate	Max. 20m ³ /h at 0-50 mPa.s in 2" housing

Diameter	Max. Flow m ³ /h
DN 50	20
DN 65	34
DN 80	51
DN 100	80



For Viscotherm® replacement a retrofit housing is available. Please refer to Information Bulletin 732.

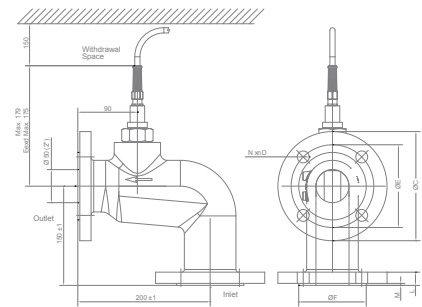

Options & accessories

Electric heater control cabinet

The EHC cabinet has been designed for automatic control of the injection viscosity of heavy fuel oil in combination with electric heaters. The control action is realised by heating the fuel oil step by step to an appropriate temperature. The built-in viscosity/temperature controller with its programmed setpoint values activates more or less heater relays. Up to six heater stages are controlled by means of relays. The first stage is controlled by means of time proportional control, which enables a linear control of power from zero to a maximum value. The power required at a certain load is adjusted by switching "ON" or "OFF" a number of stages, while the remaining fraction is added by the time proportional control.

Consult factory for more details.



Electric heater control cabinet

Applications

ViscoSense®2 systems are used in a variety of applications such as:

Marine applications

In-line viscosity control is required when (ships) diesel engines or - burners are operated on (heavy) fuel oil, since there is a large variety in quality of this fuel. A correct viscosity ensures an optimal burning efficiency of the fuel, and therefore reduces operating and maintenance costs.

Industrial applications

The ViscoSense®2 sensor is also suitable for the in-line measurement of viscosity of many liquids in industrial applications. Because individual applications need special attention please contact VAF Instruments for a tailor made solution.

Dimensions

Sensor housing

Flange type	Dimensions (mm)*				
	C	E	F	N x ØD	M
DIN PN 10/16/25/40	165	125	102	4 x 18	3
ANSI 150 RF	152,4	120,6	92	4 x 19	1,6
ANSI 300 RF	165	127	92	8 x 19	1,6
JIS 10K	155	120	100	4 x 19	2
JIS 16/20K	155	120	100	8 x 19	2
JIS 30K	165	130	105	8 x 19	2

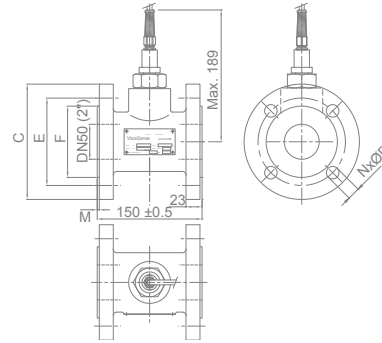

* Valid for 2" housing, other sizes on request

Signal cable length of 5 meters.

Housing DN 50

Interface box

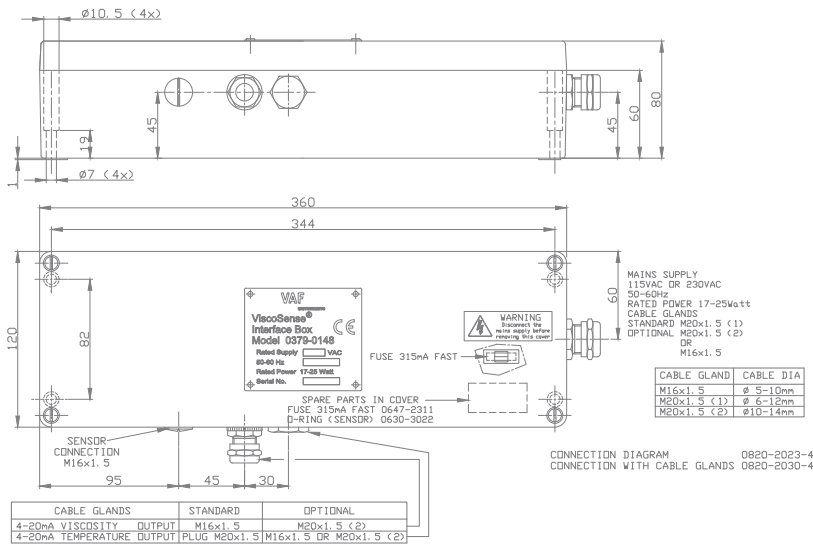

Interface box

Controller

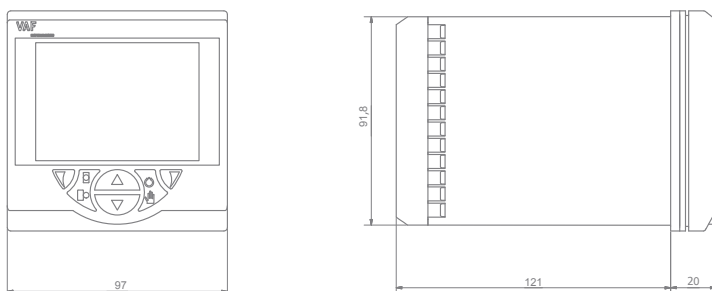

Controller

Ordering information

1. Basic system designation: ViscoSense®2			
2. Application:	<input type="radio"/> fuel viscosity control	<input type="radio"/> Viscotherm® retrofit	
	<input type="radio"/> other fluid (please indicate specifications):		
3. Viscosity range:	<input type="radio"/> 0 - 25 mPa.s	<input type="radio"/> 0 - 50 mPa.s	<input type="radio"/> special:
4. Flow rate [m³/h]:			
5. Nominal diameter of piping:			
6. Controller type:			
	<input type="radio"/> electronic with viscosity control + temperature indication	<input type="radio"/> electronic with viscosity control + temperature control	
7. Viscosity reading on electronic controller:			
	<input type="radio"/> mPa.s	<input type="radio"/> cSt	
8. Flange type:	<input type="radio"/> DIN PN [bar]	<input type="radio"/> ANSI RS [lbs]	<input type="radio"/> JIS [K]
9. Optional extras:			
<input type="radio"/> remote viscosity indicator	<input type="radio"/> viscosity recorder		
<input type="radio"/> remote viscosity indicator with alarm contacts	<input type="radio"/> viscosity recorder with alarm contacts		
<input type="radio"/> remote temperature indicator	Tagging of all system components:		
<input type="radio"/> remote temperature indicator with alarm contacts	<input type="radio"/> paper tags	<input type="radio"/> stainless steel tags	
<input type="radio"/> inspection by classification bureau	<input type="radio"/> factory calibration certificate		
Bureau name:			
10. Control valve:			
Actuation:	<input type="radio"/> electric [volt]	<input type="radio"/> pneumatic [3...15psi]	
Medium:	<input type="radio"/> steam	<input type="radio"/> thermal oil	
Body material:	<input type="radio"/> ductile iron	<input type="radio"/> steel	
Flange connections:	<input type="radio"/> DIN PN [bar]	<input type="radio"/> ANSI [lbs]	<input type="radio"/> JIS [K]
11. Nominal diameter of piping:			
12. Inlet pressure [bar]:			
13. Nominal flowrate [for steam in kg/h, liquids in m³/h]:			
14. Allowable pressure drop across valve [max. 1 bar]:			
15. Specific gravity of medium [water = 1,0]:			

Name: _____

Place and date: _____

For further information see relevant Product Bulletins or www.vaf.nl

Represented by

VAF Instruments B.V.

Vierlinghstraat 24, 3316 EL Dordrecht, The Netherlands

P.O. Box 40, 3300 AA Dordrecht, The Netherlands

T +31 (0) 78 618 3100, F +31 (0) 78 617 7068

sales@vaf.nl, www.vaf.nl

Specifications subject to change without notice.

Agents and distributors in more than 50 countries.

